

# **Programme's After Market Services NME-3 Series Transceivers**

## **General Information**

**CONTENTS**

	<b>Page No</b>
Introduction .....	3
GSM Transceiver .....	3
Modules/Accessories .....	4
Technical Overview .....	5
Technical Specification .....	8

## Introduction

The CD 949 is a fixed carphone consisting of 3 Main units.

- **GSM transceiver** – carries the main phone, it consists of a 8W GSM-transceiver, power supply, HF circuit and a SIM-Card reader for a big simcard,
- **Handset**– The handset carries a large Display, key board, earpiece and microphone and a SIM-Reader for a small simcard.
- **Cradle** – holds the handset and carries a magnet for Hook On/Off detection in the Handset.

For Downlink HF audio, 2 outputs and 1 Power amplifier drive a Loudspeaker and 1 Lineout signal to use the cars entertainment system. For modem applications it is also possible to operate the GSM Transceiver without the cradle and the handset.

## GSM Transceiver

The GSM Transceiver is the main part of the Product and carries the main GSM radio; it has 3 Connectors:

1. RF connector (GSM antenna)
2. Data Connector (Laptop)

The features of the GSM Tranceiver are listed below

1. Class 2 (8W) phase GSM 900 transceiver
2. Power supply
3. Support of ignition sense and backlightdimming signals
4. Delivery of Carradiomute and Antenna motor control signals
5. High Quality Handsfreeaudio (car enviroment)
6. Poweramplifier for 4Ω Handsfree Loudspeaker
7. Support of active Handsfree microphone according to VDA standard
8. Delivery of lineout signal to use the Car radio's amplifiers and Loudspeakers for Handsfree
9. SIM reader for large SIM-Card
10. RS-232 interface for Laptop connections (At commands)
11. Connection to Handset (via system cable)
12. Car data interface for remotecontrol and Data applications

**Modules/Accessories**

<b>Unit/type:</b>	<b>Product code:</b>	<b>Module code:</b>
<b>Transceiver (radio unit) NME-3</b>	0600128	
<b>Handset RTE-2HJ</b>	0640102	
<b>Cradle CRD-8</b>	0650028	
<b>System Module RU GM8B</b>		0201346
<b>System Module HS AH89</b>		0201345
<b>MRTE2HJ Mechanical Assembly HS</b>		0261940
<b>MNME3 Mechanical Assembly RU</b>		0261941
<b>HFM 15 Handsfree Mic.</b>	0630236	
<b>HFM10 Handsfree speaker</b>	0692006	
<b>System cable and carkit SCM-5K</b>	0730173	
<b>Mounting bracket MBE-2</b>	9457320	
<b>Swivel mount HHS-9</b>	0620037	

## Technical Overview

The mobile is built around the DCT-3 core (originally designed for a handportable phone) to operate in the GSM system. This is possible with a modest extension to the hardware as some provisions for use in a mobile are already included in the original core design. Some extensions to the original design has been necessary to be able to operate in an automotive environment, to include built-in handsfree operation and to use an active handset instead of the UI flex board of the handheld.

The purpose of the baseband module is to control the phone, process audio signals to and from the RF block and to and from the handset/handsfree transducers. The module also includes a SIM card reader and furnishes external data (RS232 and Remote control via AT commands) and VDA specific control lines like BLD, AMC, CRM and IGNS.

The entire transceiver is built on a single multilayer PCB which is enclosed in a housing consisting of a metal bottom part, metalized shield, plastic part and a plastic top cover. The shield has different chambers to separate RF from BB and to prevent trouble with Emmissions and Immunity tests during TA testing. Most components of the baseband section are surface mountable and are soldered using reflow.

The transceiver has three connectors.

- 32 pole connector which basically implements the car manufacturer recommendation for a GSM mobile phone, RU-HS connection, line-out connection.
- A 9 pole connector for data transfer.
- The RF connector for the antenna.

All internal connections on the board are by PCB wiring. The SIM card reader is soldered to the board.

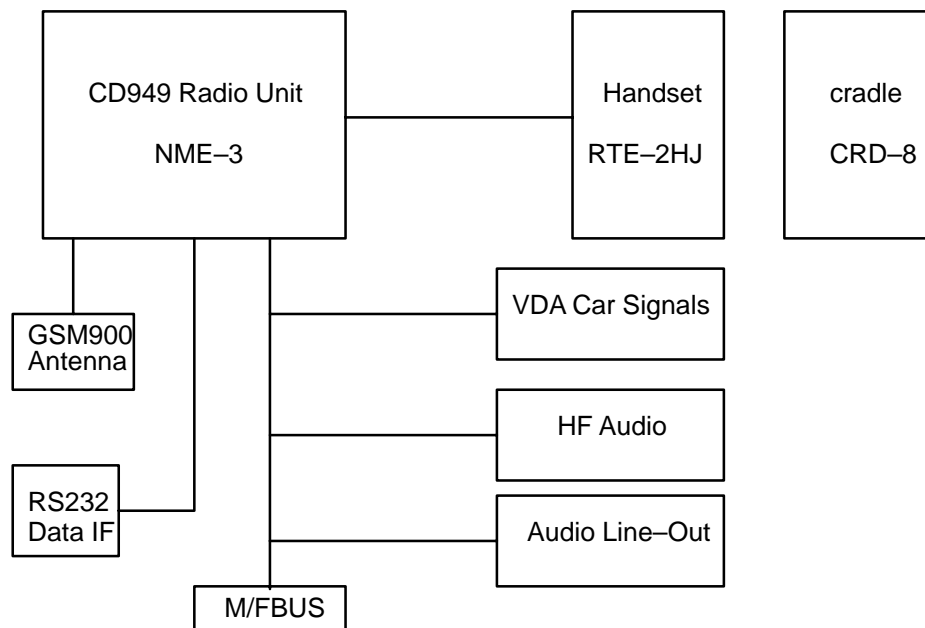

Figure 1. System Overview of CD949

The GSM Transceiver is the main part of the Product, carrying the main GSM radio. Its has 3 Connectors:

1. System connector (Powersupply , Car signals, Audiosignals, Handset Cardata)
2. RF connector (GSM antenna)
3. Data Connector (Laptop)

The features of the GSM Tranceiver are listed below

1. Class 2 (8W) phase GSM 900 transceiver
2. Powersupply
3. Support of ignition sense and backlightdimming signals
4. Delivery of Carradiomute and Antenna motor control signals
5. High Quality Handsfreeaudio (car enviroment)
6. Poweramplifier for 4Ω Handsfree Loudspeaker
7. Support of active Handsfree microphone according to VDA standard
8. Delivery of lineoutsignal to use the Carradios amplifiers and Loudspeakers for Handsfree (balanced)
9. SIM reader for large SIM-Card
10. RS-232 interface for Laptop connections
11. Connection to Handset
12. Car data interface for remotecontrol and Data applications

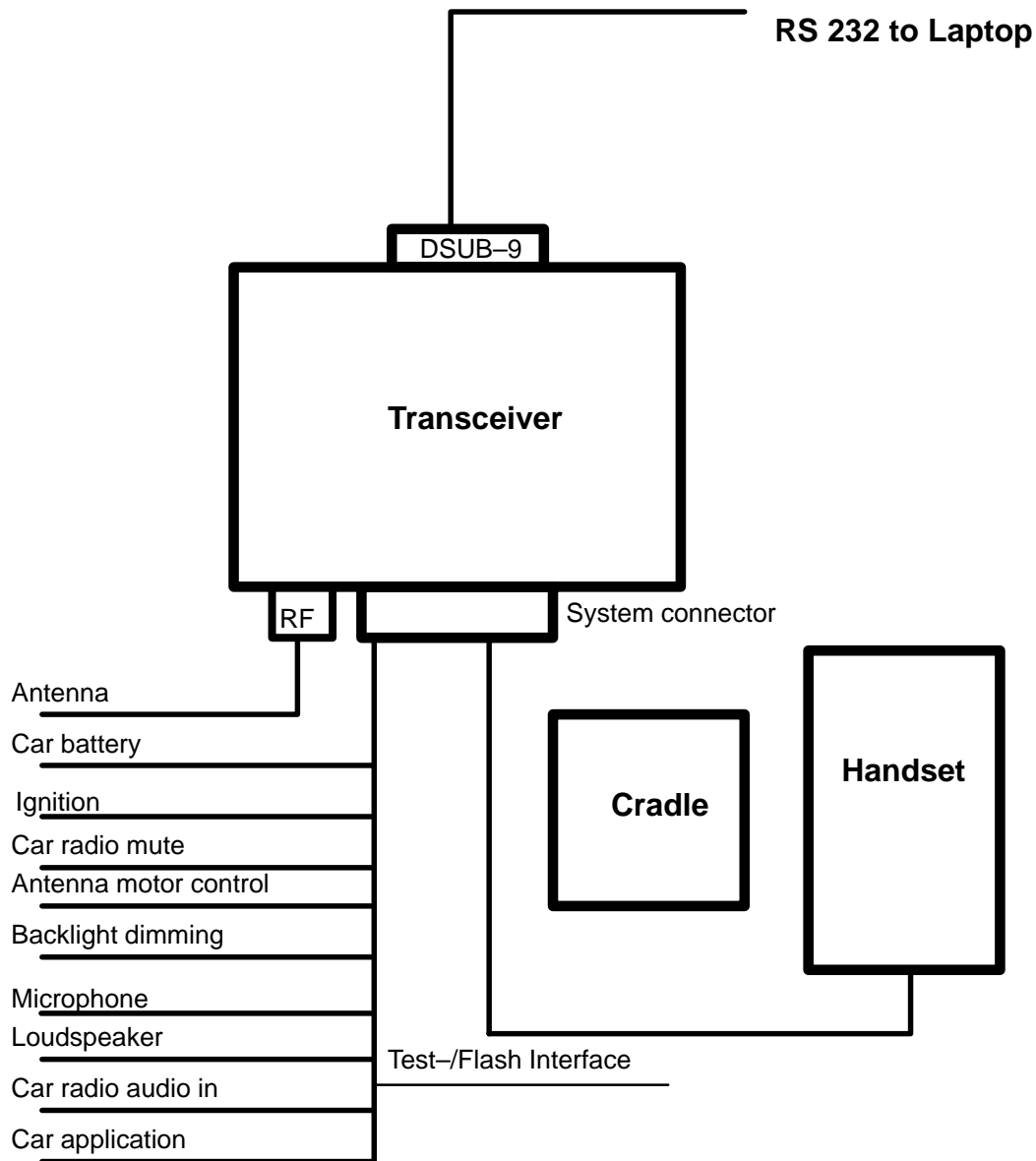

Figure 2. CD949 interconnection diagram

## Technical Specification

Parameter	Type
Cellular System	GSM 900 Phase II
Tranciever Type	Class 2 Mobile (8 Watt)
System cable Interface	32 pole AMP connector
Data Interface	RS232 (full protocoll)(DSUB 9) and Remote control via system conector (system)
Installation	Trunk, cabin or DIN slot
SIM card	Full size SIM in RU (ISO 7816) Mini SIM in HS (ISO 7816)
Operational Temperature	-20 C to + 60 C (normal performance) -40 C to + 85 C (reduced performance) -40 C to + 85 C (storage)
Supply voltage (transmitting)	10.8 V to 16 V
Current consumption (power off)	< 1mA
Current consumption (idle mode)	150mA
Current consumption (transmit at max. PWR)	normal:1,5A      maximal: 4A
Fuse	+12V Fuse 5A GND Fuse 5A IGNS Fuse 1A PCB Fuse for Fire protection
TX RF output power	8 Watt
HF Audio power	1.5 Watt at 40hm
Height	25mm
Width	170mm
Depth	115mm
Volume	489ccm